





# Welcome to the

*Thank you for showing an interest in our natural Medistone fireplaces.*

Newman Fireplaces have become synonymous with high quality fireplaces at a reasonable price, a reputation we are proud of.

As you browse through this catalogue you will find a very comprehensive range. There are styles to suit almost any room from traditional to the more contemporary including many designs that have been created from our in house design team enabling us to offer many truly unique designs that are full of style. We carefully select our natural stone for the very best available quality and ensure our fireplaces are manufactured to the highest standards using both modern and traditional methods. Our stone masons are highly skilled and many are the third generation of very talented stone masonry families.

Our Medistone natural stone has real charm and movement that create a fireplace of immense appeal each having its own unique character. We select our stone from source at the stone quarries to enable the purchase of only the very best available material.

Most of the fireplace designs shown have honed black granite hearths shown. However if a stone hearth is your preference this can be specified. For solid fuel or wood burning fires the hearth is supplied in usually three sections to allow thermal expansion for this type of appliance, for gas and electric fires one piece hearths can be used.

Please note that the fireplace models shown will include the natural stone fireplace and black granite hearth, all other products shown including, all stoves, all vermiculite boards and any other item shown in the pictures are not included in any fireplace sale, these can be purchased as optional extras if so desired. Should your requirements be to use a conventional inset fire all fireplaces in this brochure can be adapted accordingly.

We supply only to fireplace retail specialist within the UK. This has the advantage of viewing some of our products usually within close proximity to where you live. Also your chosen retailer can offer professional advice and surveys for you chosen product giving you total piece of mind, a very important part of any fireplace purchase.



## AWARDS

HEARTH & HOME

Exhibition Awards

Fireplace Product of the Year 2011

Fireplace of the Year 2011  
(Taberno Fireplace - p4)

Fireplace Suite of the Year 2011

## TELEVISION

We recently supplied a stone fireplace for the ITV show '60 minute makeover' see pictures below.

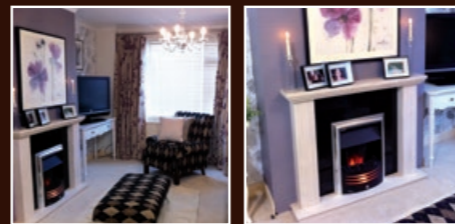

### Important:

This brochure is for the sole purpose of displaying the medistone fireplaces, all other items shown in each picture including, stoves, electric fires, down lights, vermiculite panels etc, etc, are not included in any fireplace sale. Down lights must not be used with any solid fuel or wood burning appliance. If using any solid fuel or wood burning appliance, hearths and back panels must be sectioned to allow for thermal expansion, ask your chosen fireplace retailer for further advice. Any description used to describe each fireplace is in the view of the editor only and must not be used as a factual statement.

Recent pictures from our Factory & Quarry in Portugal

# Medistone collection

## Products

- 4-5 Taberno
- 6-7 Toledo
- 8-9 Biscay
- 10-11 Catalonia
- 12-13 Barcelona
- 14-15 Tagus
- 16-17 Moncado
- 18-19 Chatille
- 20-21 Zamora
- 22-23 Palencia
- 24-25 Saville
- 26-27 Morela
- 28-29 Barosa
- 30-31 Almeria
- 32-33 Talavera
- 34-35 Coruna
- 36-37 Loja
- 38-39 Andorra
- 40-41 Cadiz
- 42-43 Murcia

### Main cover picture:

54" Morela Fireplace with Vista Quente multi fuel stove.

## Product Guide

All of our Medistone collection is manufactured from natural stone and as such, natural variation will occur. This will include shading, veining, fossils and crystal markings. This is the beauty of a natural stone product which sets it apart from any mass produced man made counterpart.

Every effort has been made to show correct colour representation, although no guarantees can be given due to the printing process. Customers are advised to view fireplaces and samples at their fireplace dealer.

Most of our Medistone range is normally suitable for compatible multi fuel or wood burning stoves & gas stoves, however subject to your chosen appliance will depend if the hearth requires sectioning & slabbing, please ask your fireplace retailer for advice.

NOTE: The Palencia model is only suitable for compatible gas or electric fires, if compatible solid fuel fires are to be used the hearth will require sectioning, please ask your fireplace retailer for advice.

Newman Fireplaces Ltd Policy is one of continuing improvement, we therefore reserve the right to alter material, design and specification without prior notice. It is strongly recommended that your chosen fireplace dealer surveys your chimney and any relevant items before purchasing any of our products.

It is advised that when the fireplace has fully dried after installation, that all surfaces are sealed with a suitable stone sealer. Ask your fireplace dealer for advice.

All Newman products should be inspected before installation, for quality and damage. No refunds can be given after this event.

All of our products must be installed by suitably qualified, competent and experienced installers complying with all relevant building regulations and any rules in force.

HETAS LOGO: The hetas logo shown applies to the corresponding stove shown.



# TABERNO

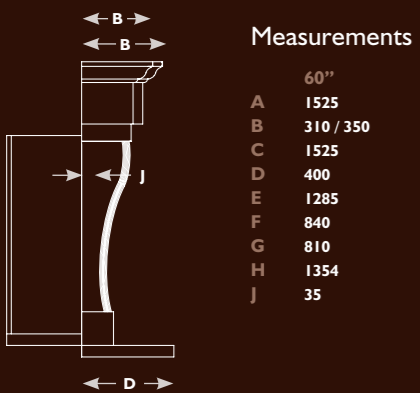
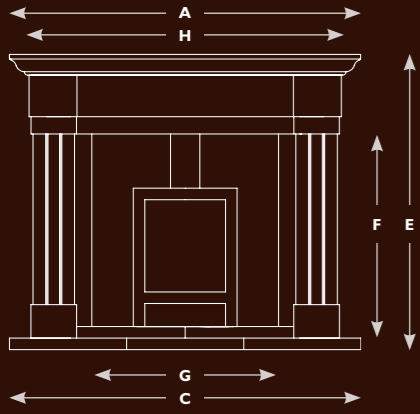

## Measurements

	60"
A	1525
B	310 / 350
C	1525
D	400
E	1285
F	840
G	810
H	1354
J	35



The Taberno must surely be a collectors piece of the future. Fireplace architecture at its very best. This design has solid stone carved shaped and fluted legs together with the curved header and shelf to give a fireplace of impressive proportions. Shown with Stoven™ Mayfair SE wood burning stove and stone pattern design to vermiculite chamber.

The Taberno fireplace incorporates a matching stone hearth but if your preference is for a honed black granite hearth, we can mix and match to your choice.

The Stoven™ Mayfair SE wood burning stove shown is unique, as this all new patented design stove incorporates the following features; separate very large panoramic curved glass panel and door, so you can enjoy watching the fire burn with maximum effect. An integral oven built into the lower part of the stove with separate door, enabling cooking, ideal for cosy nights in around the fire, also a great back up for cooking in emergency situations if there is mains supply failure. Air wash system to glass. Attractive design. 78.8% efficiency. Clean burn technology. CE approved. Smoke exempt approved, to allow burning in smoke controlled areas. The Stoven™ Mayfair SE is shown with the standard legs. Shorter legs are available as an optional extra if there are any height restraints for stove installation.

The vermiculite stone patterned chamber is also available in the following designs; Herringbone brick design, Reeded design and Brick Bond design. There is the option to select any of these designs enabling you to mix and match to your choice.



# TOLEDO

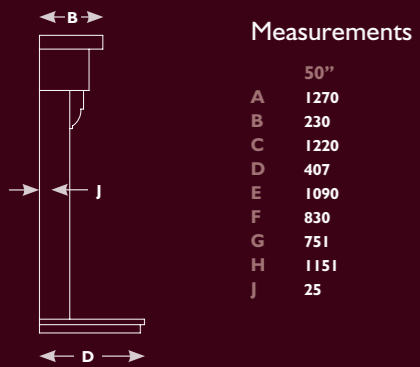
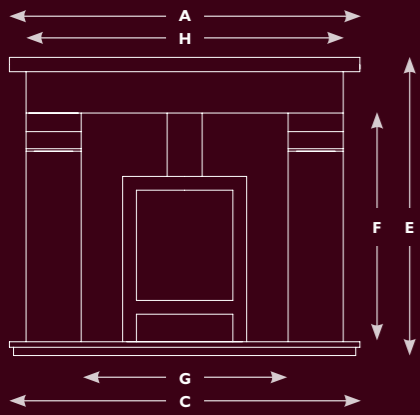

## Measurements

	50"
A	1270
B	230
C	1220
D	407
E	1090
F	830
G	751
H	1151
J	25



A very popular choice, the Toledo boasts solid stone carved corbels, a design with clean lines and great appeal. Shown with, Brick Bond pattern design to Vermiculite chamber and Vista Quente multi fuel stove.

The Toledo fireplace incorporates a honed black granite hearth, however we can supply with a matching stone hearth if so desired.

The Vermiculite Brick Bond patterned chamber is also available in the following designs, Herringbone Brick design, Reeded design and Stone design. There is the option to select any of these designs enabling you to mix and match to your choice.

The Vista Quente multi fuel stove shown, incorporates the following features: Very large glass panel to door, so you can enjoy watching the fire burn with maximum effect. Air wash system to glass. Attractive design. Up to 82% efficient when burning logs. Clean burn technology. CE approved.



# BISCAY

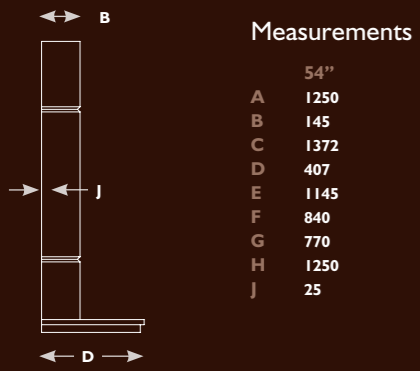
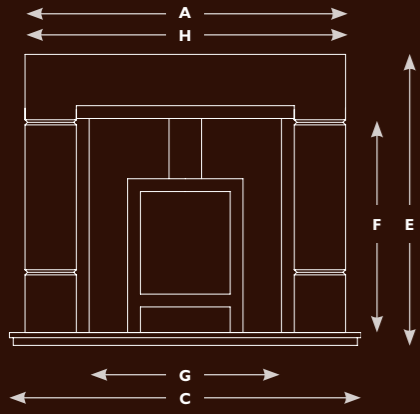

## Measurements

	54"
A	1250
B	145
C	1372
D	407
E	1145
F	840
G	770
H	1250
J	25



A masterpiece of architecture. The Biscay is carved from solid stone and boasts bold detailing to the legs combining simplicity with character, achieving a magnificent focal point to any room. Shown with Vista Panoramica multi fuel stove and Stone pattern design to Vermiculite chamber.

The Biscay fireplace incorporates a honed black granite hearth, however we can supply with a matching stone hearth if so desired.

The Vermiculite Stone patterned chamber is also available in the following designs, Herringbone Brick design, Reeded design and Brick Bond design. There is the option to select any of these designs enabling you to mix and match to your choice.

The Vista Panoramica multi fuel stove shown, incorporates the following features: Very large glass panel to door, so you can enjoy watching the fire burn with maximum effect. Air wash system to glass. Attractive design. Up to 82% efficient when burning logs. Clean burn technology. CE approved.



# CATALONIA

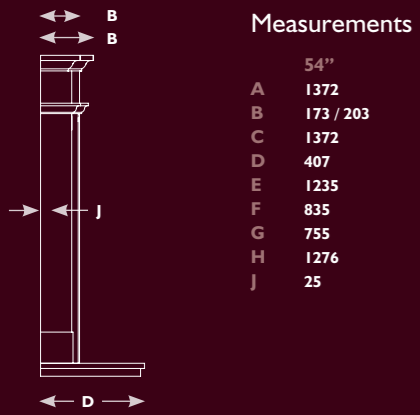
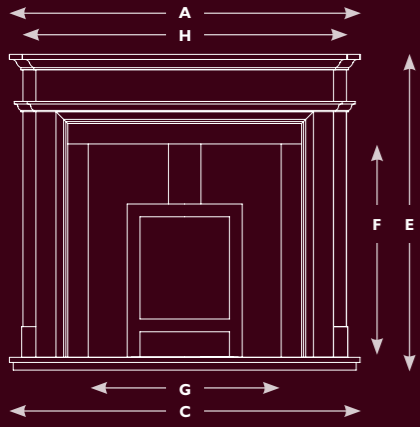

## Measurements

	54"
A	1372
B	173 / 203
C	1372
D	407
E	1235
F	835
G	755
H	1276
J	25



A beautiful fireplace of more traditional design expertly carved from natural stone. Shown with Brick Bond pattern design to Vermiculite chamber and Bela Vista multi fuel stove, also available in a gas version.

The Catalonia fireplace incorporates a honed black granite hearth, however we can supply with a matching stone hearth and slips if so desired.

The Bela Vista multi fuel stove shown, incorporates the following features: Very large ceramic glass panel to door, so you can enjoy watching the fire burn with maximum effect. Air wash system to glass. Attractive design. Up to 7.5kw nominal heat output when burning logs or 7kw when burning smokeless fuels. Clean burn technology. CE approved.

The Vermiculite Brick Bond patterned chamber is also available in the following designs, Herringbone Brick design, Reeded design and Stone design.

There is the option to select any of these designs enabling you to mix and match to your choice.



# BARCELONA

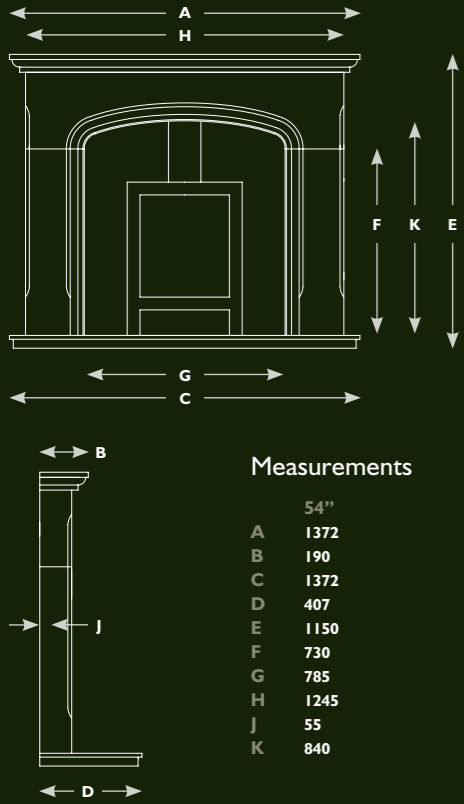

Wonderful flowing curves and fine detailing to carved profiles makes this a winning design. Sit down and admire. Shown with, Vista Quente, multi fuel stove and Reeded pattern design to Vermiculite chamber.

The Barcelona fireplace incorporates a honed black granite hearth, however we can supply with a matching stone hearth if so desired.

The Vermiculite Reeded patterned chamber is also available in the following designs, Herringbone Brick design, Brick Bond design, and Stone design. There is the option to select any of these designs enabling you to mix and match to your choice.

The Vista Quente multi fuel stove shown, incorporates the following features: Very large glass panel to door, so you can enjoy watching the fire burn with maximum effect. Air wash system to glass. Attractive design. Up to 82% efficient when burning logs. Clean burn technology. CE approved.



# TAGUS

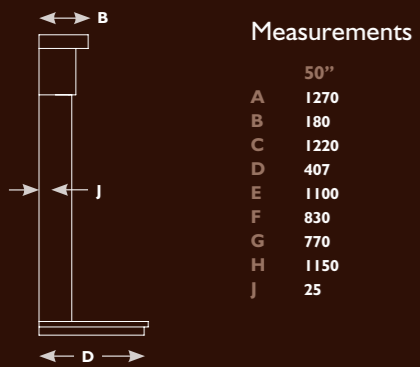
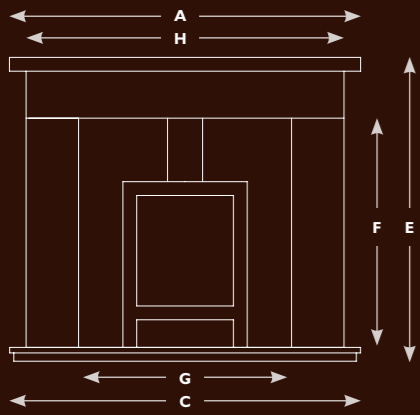

## Measurements

	50"
A	1270
B	180
C	1220
D	407
E	1100
F	830
G	770
H	1150
J	25



Straight forward styling make this fireplace of universal appeal. Ideal for both contemporary, and traditional settings. Shown with, Stoven™ Mayfair SE wood burning stove and Stone pattern design to Vermiculite chamber.

The Tagus fireplace incorporates a honed black granite hearth, however we can supply with a matching stone hearth if so desired.

The Stoven™ Mayfair SE wood burning stove shown is unique, as this all new patented design stove incorporates the following features: Separate very large panoramic curved glass panel and door, so you can enjoy watching the fire burn with maximum effect. An integral oven built into the lower part of the stove with separate door, enabling cooking, ideal for cosy nights in around the fire, also a great back up for cooking in emergency situations, if there is mains supply failure. Air wash system to glass. Attractive design. 78.8% efficiency. Clean burn technology. CE approved. Smoke exempt approved, to allow burning in smoke controlled areas. The Stoven™ Mayfair SE is shown with short legs which are an optional extra if there are any height restraints for stove installation.

The Vermiculite Stone patterned chamber is also available in the following designs, Herringbone brick design, Reeded design and Brick Bond design. There is the option to select any of these designs enabling you to mix and match to your choice.





# MONCADO

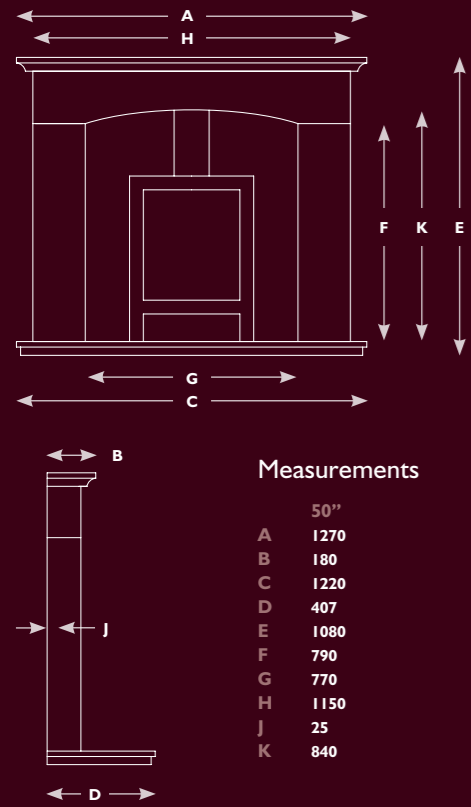

The gentle curved arch and expertly profiled shelf give this fireplace immense charm. A fireplace designed to fit most occasions. Shown with, Brick Bond pattern design to Vermiculite chamber and Vista Quente multi fuel stove.

The Moncado fireplace incorporates a honed black granite hearth, however we can supply with a matching stone hearth if so desired.

The Vermiculite Brick Bond patterned chamber is also available in the following designs, Herringbone Brick design, Reeded design and Stone design. There is the option to select any of these designs enabling you to mix and match to your choice.

The Vista Quente multi fuel stove shown, incorporates the following features: Very large glass panel to door, so you can enjoy watching the fire burn with maximum effect. Air wash system to glass. Attractive design. Up to 82% efficient when burning logs. Clean burn technology. CE approved.



# CHATILLE

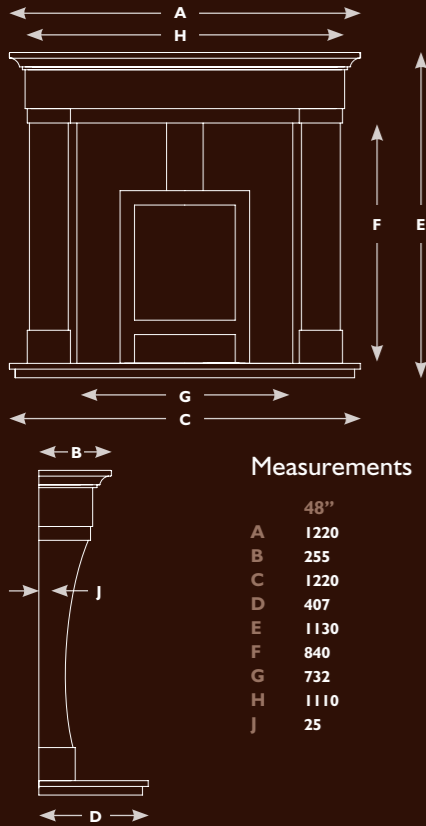

## Measurements

	48"
A	1220
B	255
C	1220
D	407
E	1130
F	840
G	732
H	1110
J	25



A modern twist to a more traditional design creates a most attractive surround. This moderately sized fireplace boasts shaped legs carved from solid stone. An appealing design, which will suit both contemporary and traditional settings. Shown with Vista Panoramica multi fuel stove and Stone pattern design to Vermiculite chamber.

The Chatille fireplace incorporates a honed black granite hearth, however we can supply with a matching stone hearth and slips if so desired.

The Vermiculite Stone patterned chamber is also available in the following designs, Herringbone Brick design, Reeded design and Brick Bond design. There is the option to select any of these designs enabling you to mix and match to your choice.

The Vista Panoramica multi fuel stove shown, incorporates the following features: Very large glass panel to door, so you can enjoy watching the fire burn with maximum effect. Air wash system to glass. Attractive design. Up to 82% efficient when burning logs. Clean burn technology. CE approved.



# ZAMORA

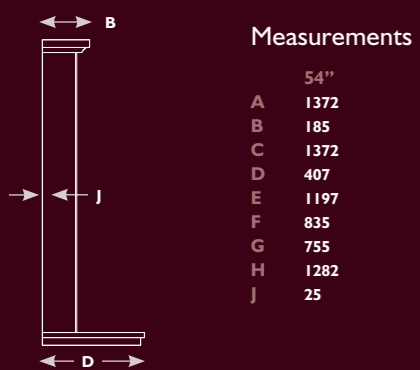
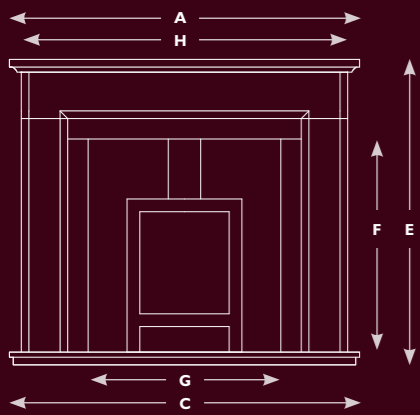

## Measurements

	54"
A	1372
B	185
C	1372
D	407
E	1197
F	835
G	755
H	1282
J	25



This fireplace has matching profiling to the frame for maximum impact. A fireplace design with clean lines and real charm will look fantastic in most room settings.

Shown with, Brick Bond pattern design to Vermiculite chamber and Bela Vista multi fuel stove, also available in a gas version.

The Zamora fireplace incorporates a honed black granite hearth, however we can supply with a matching stone hearth if so desired.

The Bela Vista multi fuel stove shown, incorporates the following features: Very large ceramic glass panel to door, so you can enjoy watching the fire burn with maximum effect. Air wash system to glass. Attractive design. Up to 7.5kw nominal heat output when burning logs or 7kw when burning smokeless fuels. Clean burn technology. CE approved.

The Vermiculite Brick Bond patterned chamber is also available in the following designs, Herringbone Brick design, Reeded design and Stone design. There is the option to select any of these designs enabling you to mix and match to your choice.



# PALENCIA

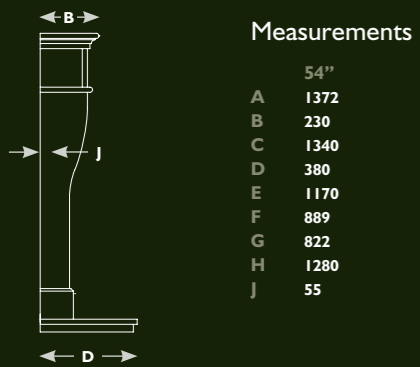
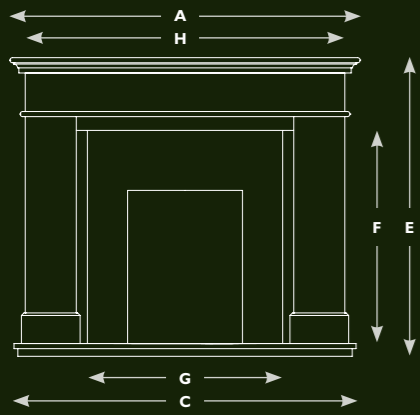

## Measurements

	54"
A	1372
B	230
C	1340
D	380
E	1170
F	889
G	822
H	1280
J	55



Gentle curving legs and subtle profiling create a fireplace of immense appeal. Shown with a three piece back panel, allowing more conventional and compatible inset fires to be used.

The Palencia fireplace incorporates a matching stone hearth but if your preference is for a honed black granite hearth, we can mix and match to your choice.

The Palencia fireplace is also available with a chamber and slip set if your preference is for a conventional stove installation as shown to other models within this brochure. Conversely all other models shown within this brochure are available with a standard three piece back panel to suit more conventional inset fires as shown to the Palencia model.

Please ask your fireplace retailer for more details.



# SAVILLE

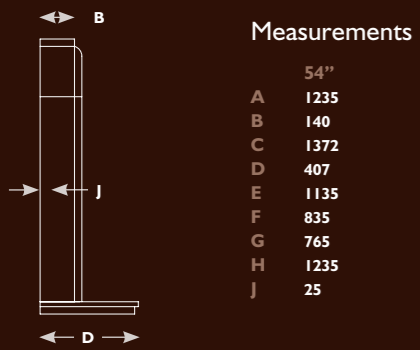
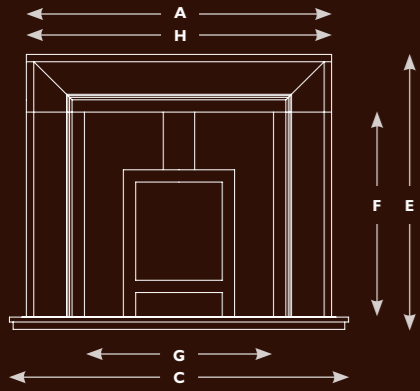

## Measurements

	54"
A	1235
B	140
C	1372
D	407
E	1135
F	835
G	765
H	1235
J	25



This Bolection styled fireplace portrays the immense skill of the stone mason. A wonderfully styled design that is sure to impress. Shown with, Vista Panoramica multi fuel stove, and Stone pattern design to Vermiculite chamber.

The Saville fireplace incorporates a honed black granite hearth and slip set, however we can supply with a matching stone hearth and slips if so desired.

The Vermiculite Stone patterned chamber is also available in the following designs, Reeded Brick design, Herringbone Brick design and Brick Bond design. There is the option to select any of these designs enabling you to mix and match to your choice.

The Vista Panoramica multi fuel stove shown, incorporates the following features: Very large glass panel to door, so you can enjoy watching the fire burn with maximum effect. Air wash system to glass. Attractive design. Up to 82% efficient when burning logs. Clean burn technology. CE approved.



# MORELA

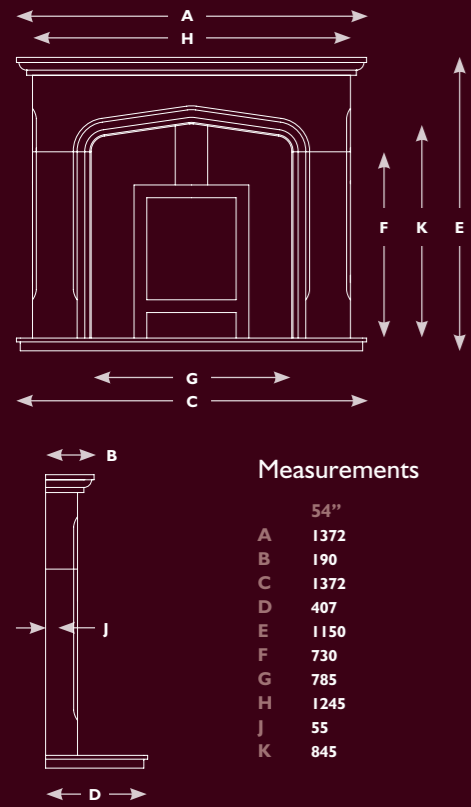

A wonderful fireplace with classical design. Elegant proportions and fine detailing will make you want to come home and enjoy this masterpiece. Shown with, Brick Bond pattern design to Vermiculite chamber and Vista Quente stove.

The Morela fireplace incorporates a honed black granite hearth, however we can supply with a matching stone hearth if so desired.

The Vermiculite Brick Bond patterned chamber is also available in the following designs, Herringbone Brick design, Reeded design and Stone design. There is the option to select any of these designs enabling you to mix and match to your choice.

The Vista Quente multi fuel stove shown, incorporates the following features: Very large glass panel to door, so you can enjoy watching the fire burn with maximum effect. Aesthetically, pleasing and up to date design. Up to 82% efficient when burning logs. Clean burn technology. CE approved.



# BAROSA

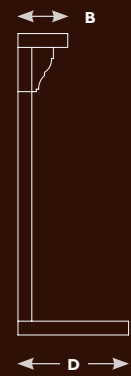
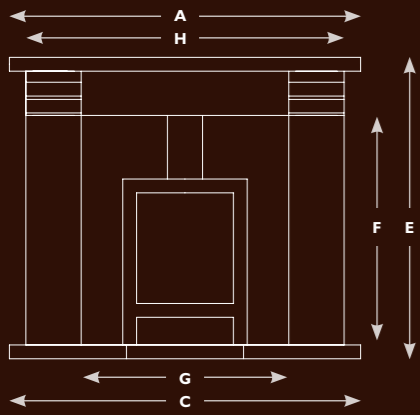

## Measurements

	50"
A	1270
B	180
C	1270
D	400
E	1090
F	830
G	751
H	1151



Solid stone carved corbels create a simple yet very attractive design, a popular design with versatility to suit most rooms. Shown with, Stoven™ Kensington SE wood burning stove with integral oven, and natural stone chamber.

The Barosa fireplace incorporates a matching stone hearth but if your preference is for a honed black granite hearth, we can mix and match to your choice.

The Stoven™ Kensington SE wood burning stove shown is unique, as this all new patent pending designed stove incorporates the following features: Separate very large panoramic curved glass panel and door, so you can enjoy watching the fire burn with maximum effect. An integral oven built into the lower part of the stove with separate door, enabling cooking, ideal for cosy nights in around the fire, also a great back up for cooking in emergency situations, if there is mains supply failure. Air wash system to glass. Attractive design. 78.8% efficiency. Clean burn technology. CE approved. Smoke exempt approved, to allow burning in smoke controlled areas. The Stoven™ Kensington SE is shown with the standard legs. Shorter legs are available as an optional extra if there are any height restraints for stove installation.

Fireplace shown with stone chamber linings also Vermiculite chambers are available for this model in the following designs, Herringbone Brick design, Reeded design and Brick Bond design. There is the option to select any of these designs enabling you to mix and match to your choice.



# ALMERIA

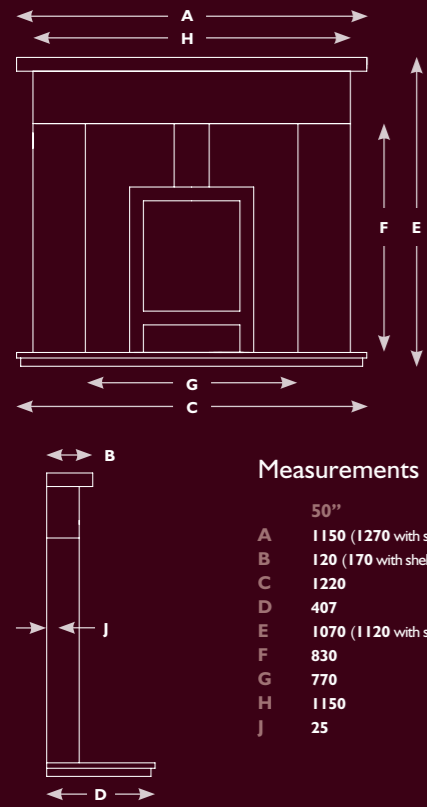

## Measurements

	50"
A	1150 (1270 with shelf)
B	120 (170 with shelf)
C	1220
D	407
E	1070 (1120 with shelf)
F	830
G	770
H	1150
J	25



A pleasant fireplace of simple design with clean cut lines and good proportions make this a popular choice. Shown with, Brick Bond pattern design to Vermiculite chamber, together with a Vista Quente multi fuel stove.

The Almeria fireplace incorporates a honed black granite hearth, however we can supply with a matching stone hearth if so desired.

The Vermiculite Brick Bond patterned chamber is also available in the following designs, Herringbone Brick design, Reeded design and Stone design. There is the option to select any of these designs enabling you to mix and match to your choice.

This model is also available with a top shelf as an optional extra.

The Vista Quente multi fuel stove shown, incorporates the following features: Very large glass panel to door, so you can enjoy watching the fire burn with maximum effect. Air wash system to glass. Attractive design. Up to 82% efficient when burning logs. Clean burn technology. CE approved. For more details of our range of stoves please see our separate Newman stove brochure.





# TALAVERA

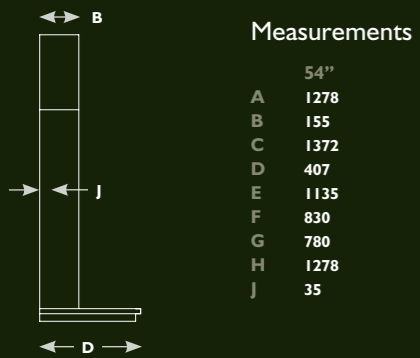
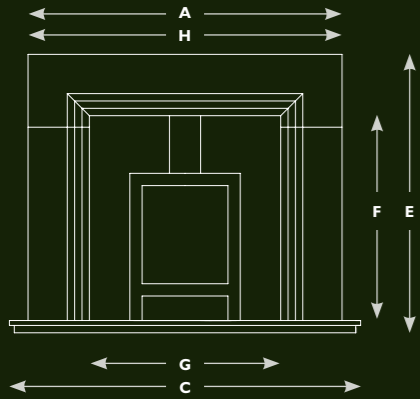

## Measurements

	54"
A	1278
B	155
C	1372
D	407
E	1135
F	830
G	780
H	1278
J	35

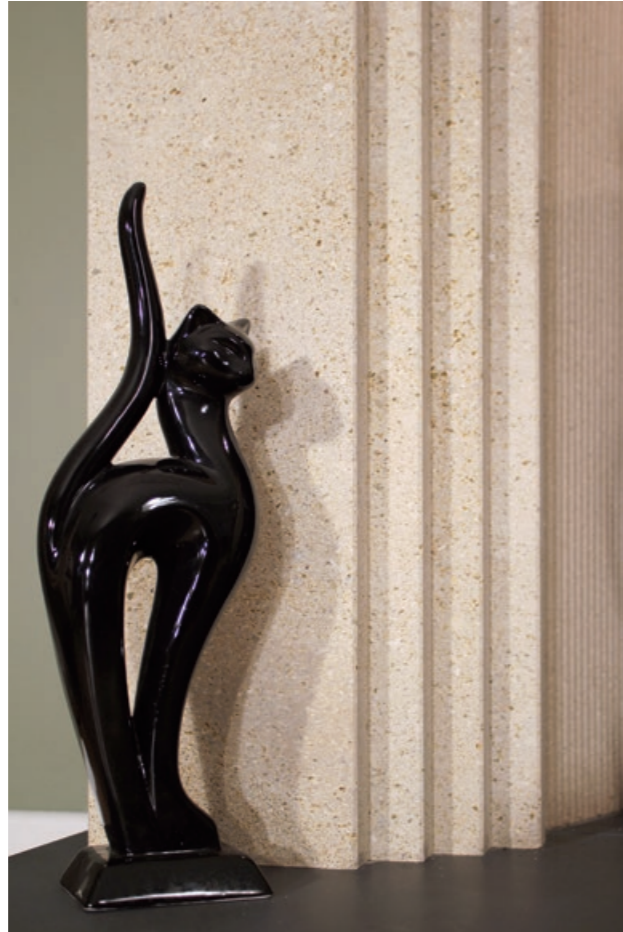

A combination of clean lines and sensational steps creates a design with extreme versatility. The Talavera will be centre stage to any living space. Shown with, Reeded pattern design to Vermiculite chamber and Vista Panoramica multi fuel stove.

The Talavera fireplace incorporates a honed black granite hearth, however we can supply with a matching stone hearth if so desired.

The Vermiculite Reeded patterned chamber is also available in the following designs, Herringbone Brick design, Stone design and Brick Bond design. There is the option to select any of these designs enabling you to mix and match to your choice.

The Vista Panoramica multi fuel stove shown, incorporates the following features: Very large glass panel to door, so you can enjoy watching the fire burn with maximum effect. Air wash system to glass. Attractive design. Up to 82% efficient when burning logs. Clean burn technology. CE approved.



# CORUNA

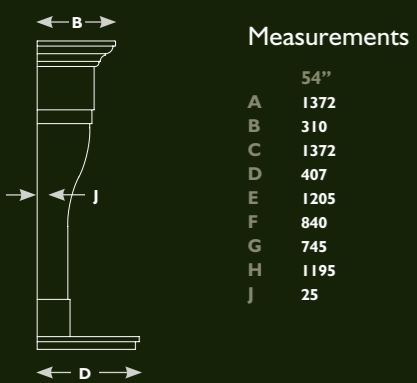
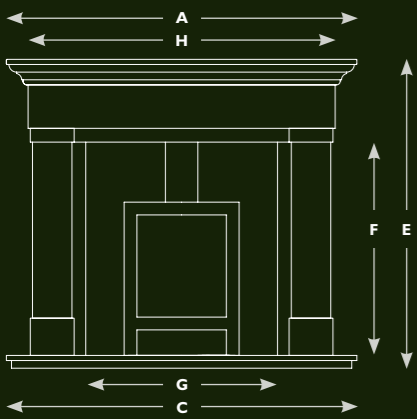

## Measurements

	54"
A	1372
B	310
C	1372
D	407
E	1205
F	840
G	745
H	1195
J	25



A striking design with French Chateau origins. Beautifully contoured legs carved from solid stone give this design, style, quality and appeal. Will transform any living space with dramatic results.

Shown with, Stoven™ Mayfair SE wood burning stove and Herringbone Brick pattern design to Vermiculite chamber. The Coruna fireplace incorporates a honed black granite hearth, however we can supply with a matching stone hearth if so desired.

The Stoven™ Mayfair SE wood burning stove shown is unique, as this all new patented design stove incorporates the following features: Separate very large panoramic curved glass panel and door, so you can enjoy watching the fire burn with maximum effect. An integral oven built into the lower part of the stove with separate door, enabling cooking, ideal for cosy nights in around the fire, also a great back up for cooking in emergency situations, if there is mains supply failure. Air wash system to glass. Attractive design. 78.8% efficiency. Clean burn technology. CE approved. Smoke exempt approved, to allow burning in smoke controlled areas. The Stoven™ Mayfair SE is shown with the standard legs. Shorter legs are available as an optional extra if there are any height restraints for stove installation.

The Vermiculite Herringbone Brick patterned chamber is also available in the following designs, Stone design, Reeded design and Brick Bond design. There is the option to select any of these designs enabling you to mix and match to your choice.



# LOJA

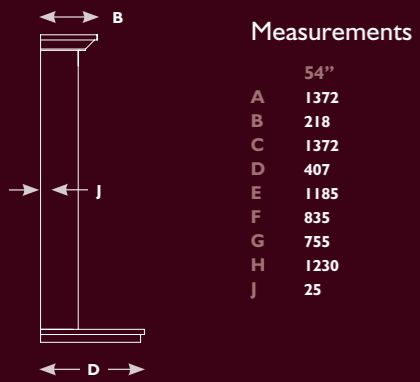
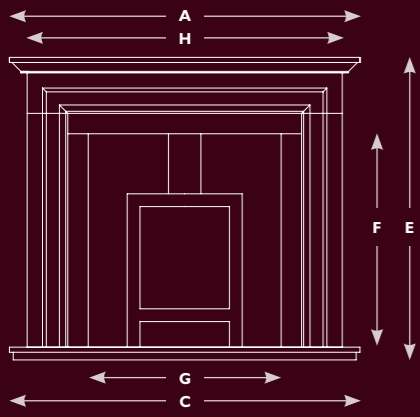

## Measurements

	54"
A	1372
B	218
C	1372
D	407
E	1185
F	835
G	755
H	1230
J	25



This wonderful fireplace will take centre stage wherever it is viewed. A design that will be, equally at home in traditional and modern surroundings. Shown with, Brick Bond pattern design to Vermiculite chamber and Bela Vista multi fuel stove, also available in a gas version.

The Loja fireplace incorporates a honed black granite hearth and slip set, however we can supply with a matching stone hearth and slips if so desired.

The Bela Vista multi fuel stove shown, incorporates the following features: Very large ceramic glass panel to door, so you can enjoy watching the fire burn with maximum effect. Air wash system to glass. Attractive design. Up to 7.5kw nominal heat output when burning logs or 7kw when burning smokeless fuels. Clean burn technology. CE approved.

The Vermiculite Brick Bond patterned chamber is also available in the following designs, Herringbone Brick design, Reeded design and Stone design. There is the option to select any of these designs enabling you to mix and match to your choice.



# ANDORRA

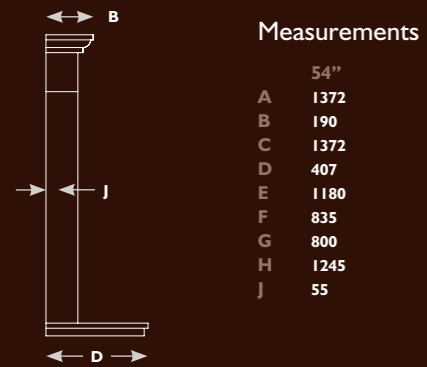
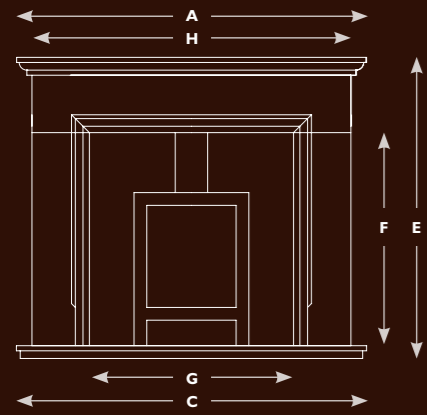

## Measurements

	54"
A	1372
B	190
C	1372
D	407
E	1180
F	835
G	800
H	1245
J	55



Sit down and relax in front of this handsome and versatile fireplace, clean lines and tasteful carved moulding make it the perfect choice. Shown with, Vista Panoramica multi fuel stove, and Stone pattern design to Vermiculite chamber.

The Andorra fireplace incorporates a honed black granite hearth, however we can supply with a matching stone hearth if so desired.

The Vermiculite Stone patterned chamber is also available in the following designs, Herringbone Brick design, Reeded design and Brick Bond design. There is the option to select any of these designs enabling you to mix and match to your choice.

The Vista Panoramica multi fuel stove shown, incorporates the following features: Very large glass panel to door, so you can enjoy watching the fire burn with maximum effect. Air wash system to glass. Attractive design. Up to 82% efficient when burning logs. Clean burn technology. CE approved.



# CADIZ

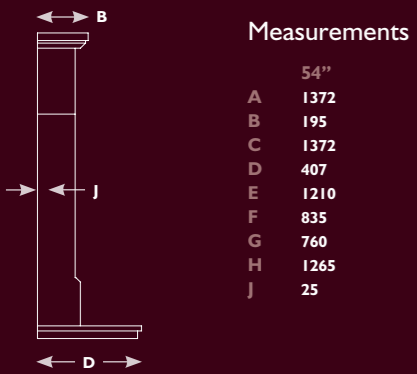
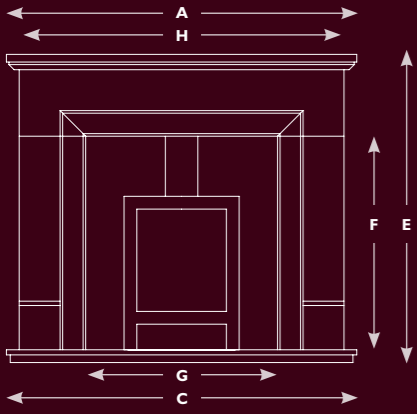

## Measurements

	54"
A	1372
B	195
C	1372
D	407
E	1210
F	835
G	760
H	1265
J	25



A striking design with a bold internal moulding creates a stunning focal point that can be admired for many years to come. Shown with a Grande Vista multi fuel stove and Brick Bond pattern design to Vermiculite chamber.

The Cadiz fireplace incorporates a honed black granite hearth, however we can supply with a matching stone hearth if so desired.

The Vermiculite Brick Bond patterned chamber is also available in the following designs, Herringbone Brick design, Reeded design and Stone design. There is the option to select any of these designs enabling you to mix and match to your choice.

The Grande Vista multi fuel stove shown incorporates the following features; very large ceramic glass panel to door so you can enjoy watching the fire burn to maximum effect. Air wash system to glass. Attractive design. Up to 75.6% efficient when burning logs. Clean burn technology. CE approved.



# MURCIA

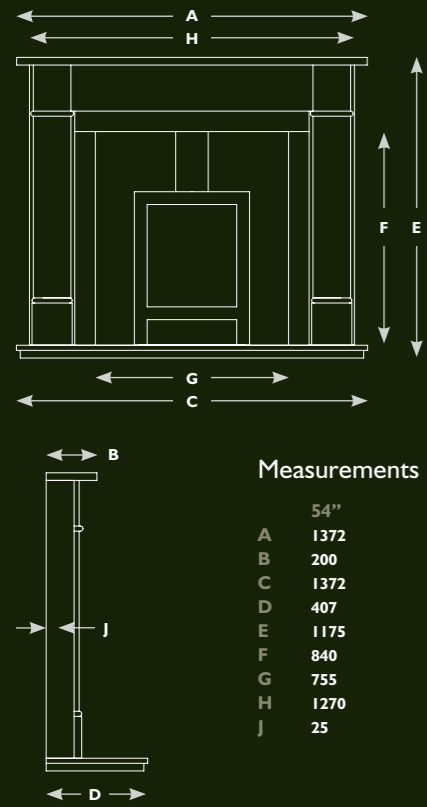

## Measurements

	54"
A	1372
B	200
C	1372
D	407
E	1175
F	840
G	755
H	1270
J	25



A classical design, with straightforward detailing make this fireplace a popular choice. Shown with, Vista Panoramica multi fuel stove, and Reeded pattern design to Vermiculite chamber.

The Murcia fireplace incorporates a honed black granite hearth and slip set, however we can supply with a matching stone hearth and slips if so desired.

The Vermiculite Reeded patterned chamber is also available in the following designs, Herringbone Brick design, Stone design and Brick Bond design. There is the option to select any of these designs enabling you to mix and match to your choice.

The Vista Panoramica multi fuel stove shown, incorporates the following features: Very large glass panel to door, so you can enjoy watching the fire burn with maximum effect. Air wash system to glass. Attractive design. Up to 82% efficient when burning logs. Clean burn technology. CE approved.





Dealer Sticker

© 2013 Newman Fireplaces Ltd

E&OE

Issue 21

£4.50



**NEWMAN**  
FIREPLACES LTD



[www.newmanfireplaces.co.uk](http://www.newmanfireplaces.co.uk)